

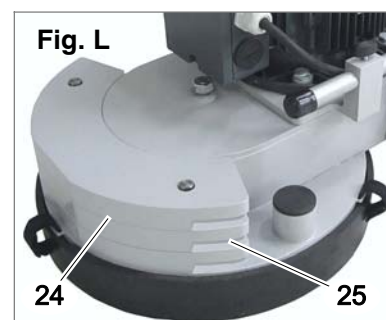

10999140\_en

<b>EN</b>	<b>Floor grinding machine FGE 400</b>	
	<b>Translation of the original operating manual</b>	<b>4</b>

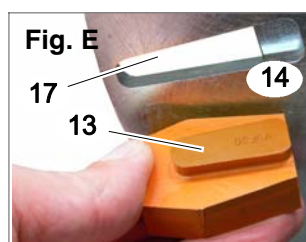

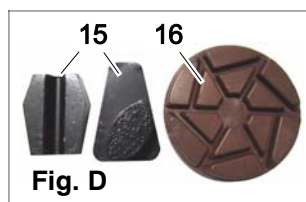
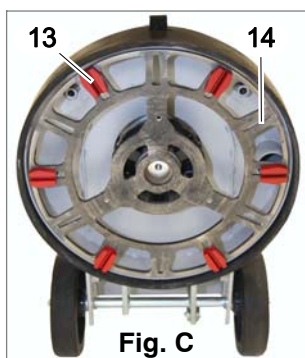
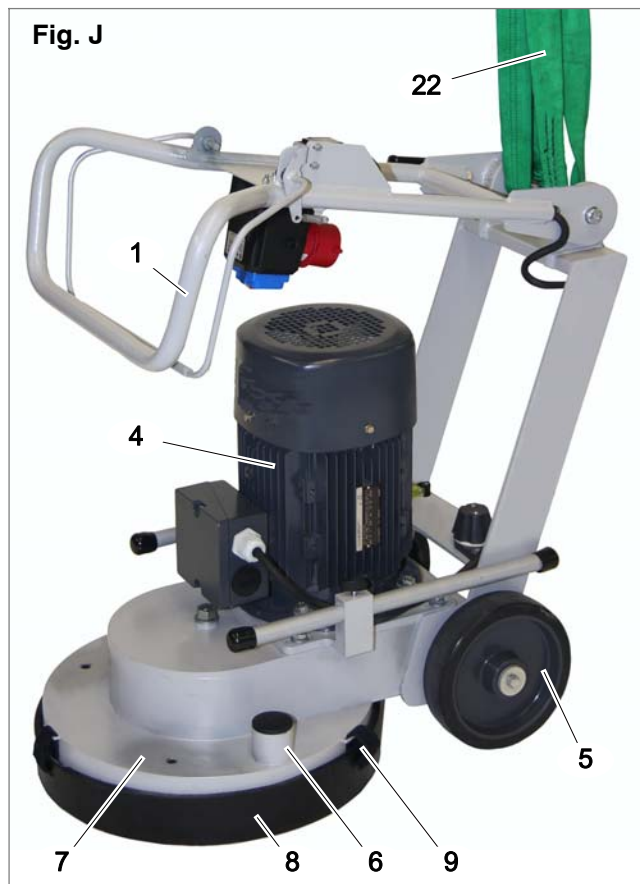
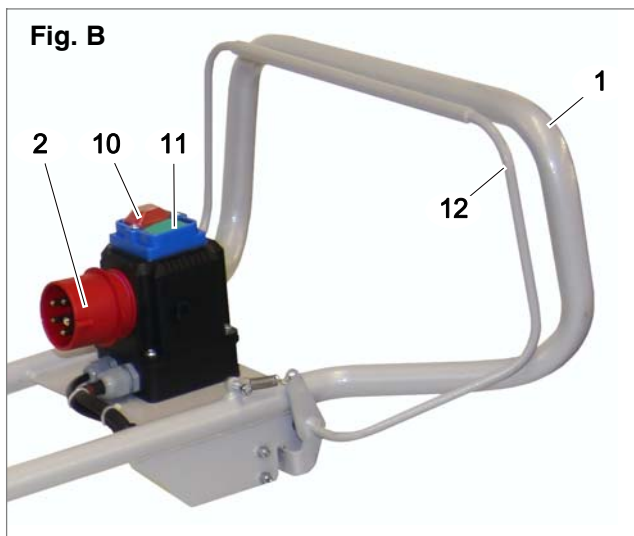
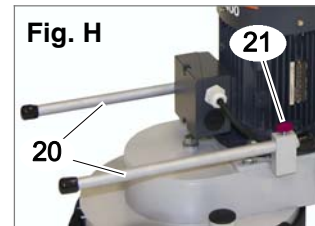
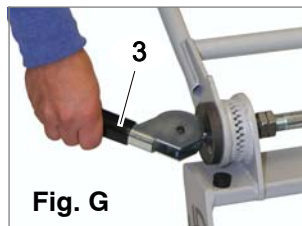
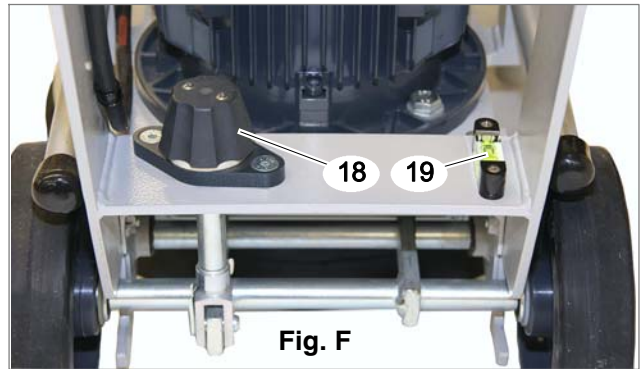
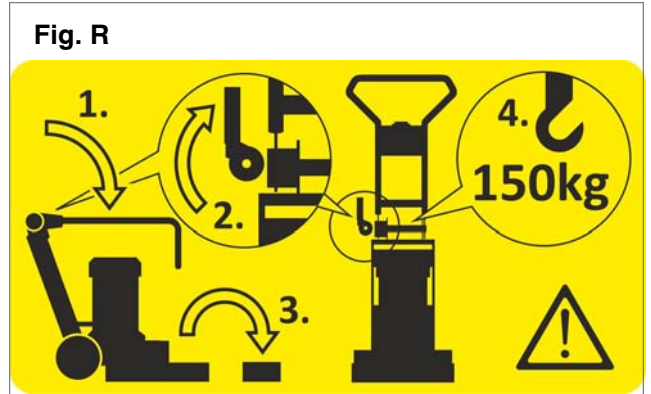
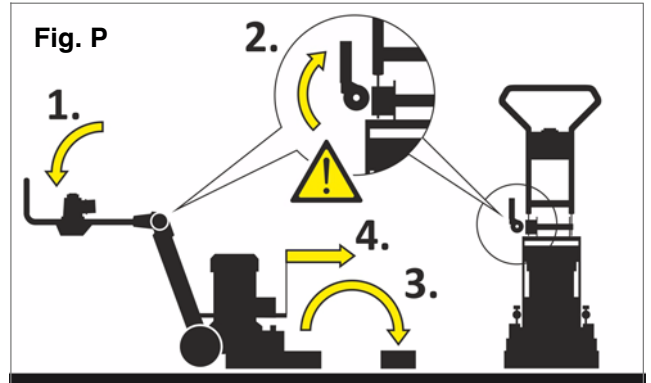
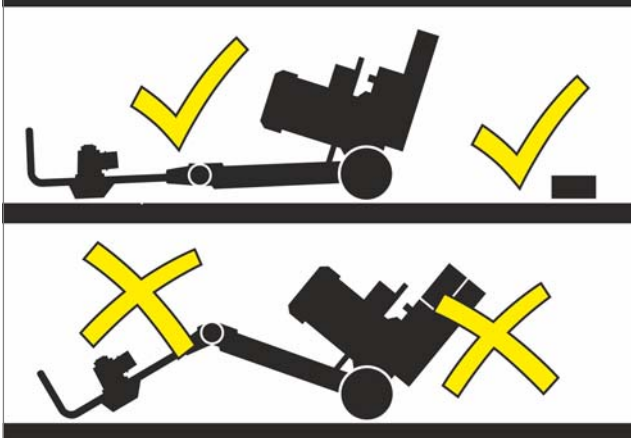
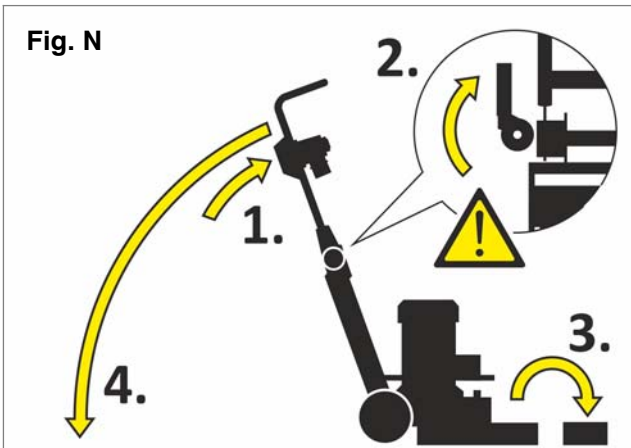
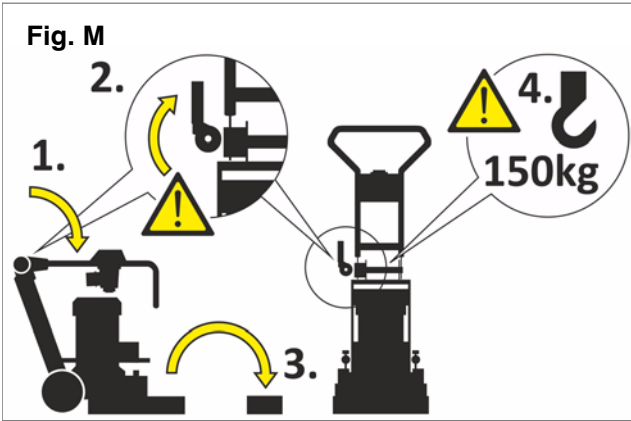

# EN Floor grinding machine FGE 400

Translation of the original operating manual

Manufacturer: TYROLIT Hydrostress AG  
Witzbergstrasse 18  
CH-8330 Pfäffikon ZH

Telephone: +41 (0)44 952 18 18  
Telefax: +41 (0)44 952 18 00  
URL: www.tyrolit.com

Document: 10999140\_en  
Publishing date: 16.01.2018

© TYROLIT Hydrostress AG  
TYROLIT Hydrostress AG reserves all rights. Any reproduction, use or distribution of this original operating manual or the translations of the original operating manual, in whole or in part, is prohibited without the express written permission of TYROLIT Hydrostress AG.

## Contents

<b>1 Important notes</b> .....	<b>5</b>
1.1 Intended use .....	5
1.2 Liability and warranty .....	5
1.3 Symbols used .....	5
<b>2 Safety</b> .....	<b>5</b>
2.1 Accident prevention and safety .....	5
2.2 Safety instructions .....	6
<b>3 Operating</b> .....	<b>7</b>
3.1 Starting up the machine .....	7
3.2 Operation .....	8
3.3 Switching the machine off .....	8
<b>4 Maintenance</b> .....	<b>9</b>
4.1 Customer service and spare parts .....	9
4.2 Attaching/Removing additional weights ..	9
4.3 Tilting the machine .....	9
4.4 Mounting and dismantling ETX diamond tools ...	9
4.5 Cleaning the machine .....	9
4.6 Checking electrical components .....	10
4.7 Final tasks .....	10
<b>5 Acceptance and transportation</b> .....	<b>10</b>
5.1 Machine acceptance .....	10
5.2 Transporting the machine .....	10
<b>6 Troubleshooting</b> .....	<b>11</b>
<b>7 Technical data</b> .....	<b>12</b>
<b>8 Declaration of Conformity</b> .....	<b>13</b>

## Key to the illustrations

Pos.	Fig.	Designation
1	A/B/J	Guide handle
2	A/B	Power plug (CEE 16 A)
3	A/G	Clamping lever
4	A/J	Drive motor
5	A/J	Transport wheel
6	A/J	Connection to the dust extraction
7	A/J	Safety hood
8	A/J	Dust cover
9	A/J	Velcro strip
10	B	OFF button
11	B	ON button
12	B	Safety handle
13	C/E	ETX diamond tool
14	C/E	ETX locating plate
17	E	ETX holder
18	F	Carriage height adjustment
19	F	Water level
20	H	Carrying bar
21	H	Knob screw
22	J	Lashing gear
15	D	Metal bonded diamonds
16	D	Synthetic resin bonded diamond pads
23	K	Bolt
24	L	Additional weight
25	L	Recessed grip



## 1 Important notes



Before using the machine, the operating personnel must carefully read and understand this operating manual! Keep this operating manual close at hand for easy reference!

Read and observe documents and operating manuals provided by suppliers!

If the machine is on loan to other parties, the operating manual needs to be provided with the machine and its importance must be made clear!

### 1.1 Intended use

The machine may be used only with the accessories supplied by the manufacturer for stripping, wet grinding, and dry grinding of even, level floor surfaces such as:

- Cement
- Screed
- Natural stone

Any other use of the machine can lead to dangerous situations and is prohibited!



**Risk of damage!**

The machine may not be used for milling bitumen surfaces (e. g. roads, footpaths)!

Bitumen can adhere to the rotor, the housing and the suction nozzle.

To ensure correct use of the machine, follow the instructions in the operating manual, paying particular attention to any warnings and instructions relating to operation and maintenance!

### 1.2 Liability and warranty

© TYROLIT Hydrostress AG

All rights, including those pertaining to translation, lie with TYROLIT Hydrostress AG.

Liability or warranty is excluded if:

- The instructions in the operating manual have not been observed.
- The machine or its attachments were improperly operated.
- The maintenance was carried out inadequately or incorrectly.
- Specified spare parts were not used.
- The safety devices were not used, have been altered or were removed.
- The specified power supply ratings and surrounding conditions have not been observed.

The manufacturer is not liable for any damage that may result if the user makes any changes to the ma-

chine without the manufacturer's permission. Any such actions will also void the warranty.

### 1.3 Symbols used

The following symbols are used in this documentation:



**Safety instructions**

This symbol indicates warnings, prohibitions and instructions regarding potential hazards. These instructions must be obeyed and closely observed.

Some safety instructions are accompanied by corresponding symbols.



Warning



Prohibition



Direction



**Additional information**

This symbol indicates additional information.

## 2 Safety

This chapter contains a summary of the most important information on safety when handling the machine.

### 2.1 Accident prevention and safety

The following instructions comply with legislation, directives, and publications including:

- EC Machinery Directive
- EC General Product Safety Directive
- Law governing technical materials
- Law governing equipment safety
- Law governing product liability



This operating manual is intended for operators and tool setters, as well as for the personnel that service, maintain and repair the machine. Together with all the technical documentation, it is intended to help

- avoid hazardous situations
- use the machine for its intended applications
- avoid downtime and repair costs
- maintain the function of the machine
- extend the service life of the machine.

The manufacturer and owner of the machine must respect the contents and regulations of the EC directives. The effectiveness of any measure ultimately depends on how well all parties, i.e. the manufacturer, the owner and the machine operators, work together to uphold safety standards.

### 2.2 Safety instructions

This machine incorporates state of the art technology and has been built in accordance with recognised safety regulations. This ensures that the highest possible standards of occupational safety are maintained. However, incorrect use of the machine could endanger the health and lives of the personnel or cause material damage.

-  All laws and regulations (e.g. the valid regulations on waste disposal), accident prevention guidelines and generally recognised safety rules must be complied with when working on and with the machine.
-  The surfaces to be processed by the machine need to be free of obstacles and loose parts.
-  A general inspection of the machine must be conducted before starting up the machine. Particular attention should be paid to damaged or loose components, and wear.

The machine may only be put into operation in perfect technical condition.

If any defects are found in the machine that could endanger people or damage property, stop the machine immediately and ensure that it cannot be used again until all repairs are completed.

Warning signs [→ Fig. R] must be in a legible condition!



-  Adding to or modifying the machine in any way that could compromise operating safety is prohibited!



-  Risk of injury if safety devices have been removed or are non-functional!

The safety devices must be checked for completeness and function before starting up.

The safety devices must be mounted during operation.

-  Do not operate the machine in areas where there is risk of explosion or where flammable materials are present.
-  The machine may only be operated by people who have been assigned to do so and who have the appropriate training and skills.



-  The operating and maintenance personnel responsible for the machine must ensure that no one can enter the machine's danger zone during operation or maintenance work.



-  Risk of injury from rotating machine parts! Limbs and clothing can be drawn in. Proceed with the greatest care and caution!



-  Risk of injury from dust formation during grinding work! Connect an extractor unit to the machine or feed in water during the grinding process. Wear respiratory protection!



-  Risk of poisoning due to harmful substances at the workplace! Eating, drinking and smoking at the workplace is not permitted. Always eat in break rooms or canteen areas!



- ⚠ High-voltage electrical current can be fatal! Only connect the machine to power supplies equipped with a ground fault circuit breaker!. Connections with mains cables need to be protected from splash water!
- ⚠ When working on the machine (set-up, maintenance, service, repair, cleaning, etc.), the power supply of the machine has to be disconnected from the mains (disconnect power plug)!
- ⚠ Only suitably knowledgeable, qualified professional electricians may perform work on any electrical parts of the system.
- ⚠ Cleaning and maintenance may be done only by trained personnel.  
Maintenance needs to be conducted according to the operation manual.
- ⚠ After completing the work, thoroughly clean yourself!

### 3 Operating

- ⚠ Follow the safety instructions in Chapter 2.



- ⚠ Risk of injury from parts flung out during grinding! Wear protective clothing and protective goggles. Wear safety shoes and protective gloves! Proceed with the greatest care and caution!
- ⚠ Danger of injury from loud noise during grinding operation of the machine! Always wear hearing protection when the machine is in operation!







- ⚠ High-voltage electrical current can be fatal! Take care not to run over, crush or pull on the mains cable!

#### 3.1 Starting up the machine



- ⚠ The initial start-up of the machine may be carried out only by qualified personnel.  
A visual inspection of the machine needs to be carried out before starting up the machine. Particular attention should be paid to damaged or loose components, and wear.

Always use ETX diamond tools or abrasive bonding that are suitable for the given surface to be machined (e.g. some surfaces have to be ground wet).

1. Disconnect the power plug [2, Fig. A] from the mains.
  2. Check ETX diamond tools for function and condition and replace if necessary. (→ Chapter 4.4 - page 9).
  3. Check the surface to be ground and remove any protruding objects.
  4. Attach external dust extraction at the connections to the dust extraction [6, Fig. A].
  5. Grip the guide handle [1, Fig. A] or secure against dropping and open the clamping lever [3, Fig. G].  
✓ The guide handle is unlocked.
  6. Set the guide handle to the desired position.  
**i** — **Operation** is carried out in the standard position [→ Fig. A].  
— The stretched position is intended for **tool change** and for **maintenance**. The machine can then be tilted backward.  
— For **transporting** the machine, the guide handle can be swivelled to the front position [→ Fig. J/M/R].
  7. Close the clamping lever.  
✓ The guide handle is locked.
  8. Place the grinding tool on the surface to be ground.
  9. If necessary, attach additional weights (→ Chapter 4.2).
- ⚠ Always bring the machine to a stop before actuating the carriage height adjustment!







10. Turn the carriage height adjustment [18, Fig. F] until the machine is aligned horizontally according to the built-in water level [19, Fig. F].
11. Check the dust cover [8, Fig. A/J] for proper position and function and, if necessary, correct or exchange.
  -  There should be a 3 ... 4 mm gap between the dust cover and the grinding surface.
12. Check the safety devices for completeness and function before starting up.
  -  Risk of damage due to crushing or exerting tensile strain on the mains cable and the suction hose!
  -  The electric outlet serving as the power supply should be supported and installed according to local regulations.
  -  Risk of injury from inadvertent starting of the machine!  
Before plugging in the power plug, make sure the machine is switched off.
13. Join the connecting cable (extension cable) with the proper power socket and plug the connection cable's coupling in the power plug [2, Fig. A].

### 3.2 Operation

-  Follow the safety instructions in Chapter 2.
  -  Risk of damage due to uncontrolled movement of the machine!  
Before actuating the safety handle, grip the machine with both hands on the guide handle! On a slope, the machine can quickly accelerate out of the operator's control, and due to the high centre of gravity, it could also tip over! If necessary, use suitable auxiliary equipment (e. g. cable winch)!  
The machine can suddenly turn to the side when it is started up! Make sure that it is standing securely and that the guide handle is in the correct position!
  -  When the machine is in operation, do not touch any part of the machine outside the gripping range of the guide handle [1, Fig. A/B]!
1. If necessary, feed in water onto surfaces that are to be ground wet.
  2. Hold the machine by the guide handle.
  3. Press the safety handle [12, Fig. B] against the guide handle and grip in place.
  4. Press the ON button [11, Fig. B].

-  The drive is switched on.  
The ETX locating plate rotates [14, Fig. C].  
The surface to be ground can now be machined.

### 3.3 Switching the machine off

-  Risk of injury from a still rotating ETX locating plate even after the machine is switched off!  
The tool mount can continue to turn in idle (run-on) for several seconds after switch off!  
When the tools have been set down on the floor and the machine is switched off, even after switching off or releasing the safety handle, the machine can still turn by as much as 60° on its own axis.
  -  Do not release the guide handle until the ETX locating plate is no longer turning!
1. Release the safety handle [12, Fig. B] and wait for the ETX-locating plate to come to a full stop.
    -  If the ETX locating plate continues to rotate (defective), press the red OFF button or pull the power plug.
    -  The drive has been switched off.  
The ETX locating plate is no longer rotating.
  2. Press the red OFF button [10, Fig. B].
    -  The machine is switched off.
    -  Risk of injury from high voltage!  
There is still residual voltage even after the machine has been switched off.  
The power supply has to be disconnected to remove all voltage (disconnect power plug)!





## 4 Maintenance

---

 Follow the safety instructions in Chapter 2!



 The operating and maintenance personnel responsible for the machine must ensure that no one can enter the machine's danger zone during operation or maintenance work.

 Maintenance work may only be performed by trained specialists! They must be familiar with the dangers associated with such work, protect themselves and avoid danger!

 When working on the machine (set-up, maintenance, service, repair, cleaning, etc.), the power supply of the machine has to be disconnected from the mains (disconnect the plug) and the drive must be at a standstill!

 Perform cleaning and maintenance work in accordance with the operating manual and check the safety devices for completeness and functionality.

### 4.1 Customer service and spare parts

---

In case of customer service queries, replacement parts or repairs, please contact the manufacturer. To ensure your queries are dealt with as quickly as possible, always quote your machine data. These are located on the machine's nameplate.

### 4.2 Attaching/Removing additional weights

---

 Risk of injury from heavy additional weights! Only grip the additional weights at the recessed handles [25, Fig. L]! Work with care!

1. Screw 2 bolts [23, Fig. K, spanner size 13] into the safety hood [7, Fig. J].
2. As needed, grip 1 ... 3 additional weights [24, Fig. L] and slide these over the bolts.

 The removal is carried out in logical reverse order.

### 4.3 Tilting the machine

---

 Before tilting the machine, always make sure that it is on an even, level floor surface!

1. Disconnect the power plug [2, Fig. A] from the mains.
2. Swivel and lock the guide handle [1, Fig. A] in the stretched position (→ Chapter 3.1).
3. Remove additional weights (→ Chapter 4.2).
4. Tip the machine and place it on the floor (→ Fig. C/N/R).

### 4.4 Mounting and dismantling ETX diamond tools

---

The consistency of the surface to be ground determines the type or composition of the tools to be used.

 All of the ETX diamond tools [→ Fig. D] authorized for this machine are removed and mounted in the same manner.

 Always mount tools of the same type according to the processing specifications. The heights of the diamond tools (degree of wear) must be the same.

1. Tilt the machine (→ Chapter 4.3).
2. Gently tap with a lump hammer to loosen the tools [13, Fig. E] from the EXT locating plate [14, Fig. C/E] in the direction of the centre and then remove.
3. Insert new tools in the ETX holder [17, Fig. E] and press toward the outer edge of the ETX locating plate (use lump hammer if necessary).
4. Set the machine upright, swivel and lock the guide handle in standard position (→ Chapter 3.1).

### 4.5 Cleaning the machine

---

 Do not use high pressure cleaners or compressed air to clean the machine!

1. Tilt the machine (→ Chapter 4.3).
2. After use, clean the machine and tools with a dry method such as a vacuum cleaner with a suitable filter, a cloth or a brush.
3. Set the machine upright, swivel and lock the guide handle in standard position (→ Chapter 3.1).

## 4.6 Checking electrical components

 Only suitably knowledgeable, qualified professional electricians may perform work on any electrical components of the machine.

 Risk of fire due to faulty electrical cables!

- Check the mains cable and power plug regularly for functional safety.

## 4.7 Final tasks

Either decommission the machine

- Disconnect the power plug [2, Fig. A] from the mains.

Reduce the projection if necessary:

- Swivel the guide handle into the front position (over the drive motor) and lock it in place (→ Chapter 3.1, Fig. J/M/R).

or

- Restart the machine (→ Chapter 3.1).

# 5 Acceptance and transportation

 Follow the safety instructions in Chapter 2.

## 5.1 Machine acceptance

The packaged machine is supplied complete from the manufacturer.

1. Unpack machine and check the delivery slip to make sure all parts are delivered.
2. Check for any transportation damage.
3. In case of damage, contact the transport company promptly.
4. Report any problems to the manufacturer immediately.

 Complaints at a later date cannot be acknowledged!

## 5.2 Transporting the machine



 The machine may only be transported if it has been switched off and the ETX locating plate is at a standstill!

 Risk of injury from heavy loads! Suspended loads can slide out of place, fall or tip over and cause serious injuries.

**Never walk under or reach under suspended loads!**

**Raising and lowering the load must be performed by two persons!**

**Do not raise loads any higher than necessary!**

**Prevent the load from swinging back and forth!**

**Keep sufficient safety distance.**

Devices for transporting the unit have to be rated to handle its full weight and dimensions.

Observe weight data on packaging or in the accompanying documentation.

**Do not lift any additional loads together with the machine!**

**Wear safety shoes!**

**Wear safety gloves!**

**During transport, the guide handle [1, Fig. A/J] must always be locked in position [3, Fig. G/M/R] with the clamping lever!**

**The crane hook or lashing gear may only be attached at the specified position**

[→ Fig. J/M/R]!

The machine can be fastened to pallets to protect it against damages. A relocation over shorter distances is possible on the transport wheels.

1. Switch off the machine (→ Chapter 3.3).

2. Fasten any loose parts to the machine.

3. **Either** (moving machine over short distances)

- Move the machine to the respective location with the transport wheels [5, Fig. A/J] and deposit.

or

(hoisting or carrying the machine over short distances, **2 people**)

- a. Remove additional weights (→ Chapter 4.2).
- b. Loosen the knob screws [21, Fig. H], slide the carrying rods to the front [20, Fig. H] and then tighten the knob screws again.
- c. Grip the machine by the guide handle and the carrying rods (→ Fig. P), move it to the respective location, and set it down.
- d. Loosen the knob screws, slide the carrying rods to the back, and tighten the knob screws again.



or

(for transport over longer distances)

- a. Remove the additional weights (→ Chapter 4.2) or fasten them securely to the machine (e.g. lash them on with tension belts).
- b. Swivel the guide handle into the front position (over the drive motor) and lock it in place (→ Chapter 3.1, Fig. J/M/R).
- c. Use suitable lashing gear to hoist the machine (→ Fig. J/M/R) and lower it onto a suitable transport device (e.g. a pallet).



**The grinding plate and the wheels must rest on the transport device!**

- d. When transporting the machine with a vehicle or suitable transport device, always ensure that the machine is secured (e.g. strapped in with tension belts) according to regulations.
- e. Move the machine to the respective location and set it down.



**For longer transports or longer storage, the machine needs to be covered to protect against soiling.**

## 6 Declaration of Conformity

TYROLIT Hydrostress AG  
Witzbergstrasse 18  
CH-8330 Pfäffikon ZH  
Switzerland

We hereby declare that the machine  
**FGE 400**

complies with the provisions described in

- Directive 2006/42/EG  
Machine
- Directive 2014/30/EU  
Electromagnetic Compatibility

The following harmonised standards apply:

- ISO 12100  
Safety of Machinery
- EN 60204-1  
Electrical Equipment of Machines
- EN 61000-6-2/EN 61000-6-4  
Electromagnetic Compatibility

**This declaration is no longer valid if the machine is modified or retrofitted without our prior consent and approval.**

Pfäffikon, den 16.1.2018

Pascal Schmid  
Development manager and responsible for the  
technical documentation

## 7 Troubleshooting

**i** Only suitably knowledgeable, qualified professional technicians may perform repairs on the machine.

Malfunction	Cause	Rectification
Machine will not start.	The voltage supply has not been properly connected.	Join the connecting cable (extension cable) with the proper power socket and plug the connection cable's coupling in the power plug [2, Fig. A].
	Connecting cable is defective.	Replace connecting cable.
	Safety handle [12, Fig. B] is defective.	Repair or replace safety handle.
When using an extraction, the suction housing sucks itself to the floor.	Distance between rubber ring and the surface to be ground is too little.	Correct the distance between rubber lip and the surface to be ground (→ Chapter 3.1).
Grinding pattern is uneven.	Tools are loose.	Fasten tools.
	Tools are damaged or worn.	Replace tools.
Machine shuts down by itself.	Machine is overloaded. The drive overload protection (MOP) has triggered.	<ul style="list-style-type: none"> <li>— Select other tools if necessary (→ Chapter 4.4 - page 9).</li> <li>— Reset:                             <ul style="list-style-type: none"> <li>a. Disconnect the power plug [2, Fig. A] from the mains.</li> <li>b. Wait 30 seconds.</li> <li>c. Restart the machine (→ Chapter 3.1).</li> </ul> </li> </ul>
	Connecting cable (extension cable) is too long.	The minimum cross section and the maximum length of the connecting cable (extension cable) → Chapter 8
	Faulty power supply.	<p>Check the connecting cable (extension cable) and replace if necessary.</p> <p>Use a different power socket if necessary.</p>
Drive motor is turning, but the ETX locating plate is not turning.	Toothed belt is loose or torn.	Tighten or replace toothed belt. Please contact the manufacturer.



## 8 Technical data

Designation	FGE 400
Rated voltage	400 V, 3~
Rated frequency	50 Hz
Rated current	8,5 A
Rated power	(6) 4 kW
Connecting cable	5 x min. 2,5 mm <sup>2</sup> (max. 25 m) 5 x min. 4,0 mm <sup>2</sup> (>25 m)
Tool speed	900 rpm
Protection rating	IP 23
Dust extraction	Ø 50 mm
Dimensions (L x W x H)	ca. 650 x 450 x 750 mm
Working width	Ø 400 mm
ETX locating plate	Ø 400 mm
Edge distance	min. 10 mm
Grinding pressure	32 ... 64 kg
Weight	109 kg
Noise level	79 dB(A)
Vibration total value *)	≤ 2,5 m/s <sup>2</sup>

\*) determined under standardised manufacturer operation conditions according to measuring method HARM.



**TYROLIT Hydrostress AG**  
Witzbergstrasse 18  
CH-8330 Pfäffikon ZH  
Switzerland  
Telefon: +41 (0)44 952 18 18  
Telefax: +41 (0)44 952 18 00  
URL: [www.tyrolit.com](http://www.tyrolit.com)