

# ***Operating Instructions***

## ***Spare parts list***

---

### ***AU Drive Unit***

*Index 004*

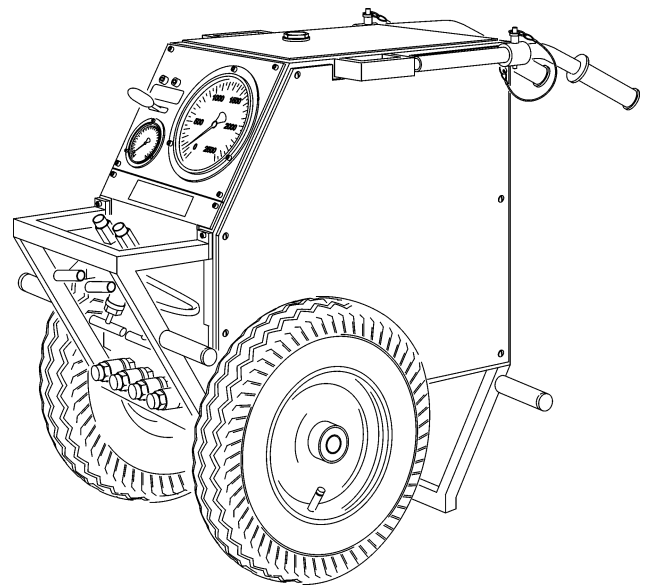

**Manufacturer's address:**

**TYROLIT Hydrostress AG**  
**Witzbergstrasse 18**  
**CH-8330 Pfäffikon**  
**Switzerland**  
**Phone +41 (0) 44 / 952 18 18**  
**Fax +41 (0) 44 / 952 18 00**

TYROLIT Hydrostress AG reserves the right to make technical changes without prior notice.

Copyright © 2009 TYROLIT Hydrostress AG, CH-8330 Pfäffikon ZH

All rights reserved, in particular the copying and translation rights.

The reprinting of these Operating Instructions, including extracts, is prohibited. No part of these Operating Instructions may be reproduced in any form whatsoever or be processed, copied or distributed using electronic systems without the written permission of TYROLIT Hydrostress AG.

# Overview

	Page
<b>0 Introduction</b>	<b>1</b>
0.1 Congratulations!- - - - -	1
0.2 Validity of these Operating Instructions - - - - -	2
0.3 Standards - - - - -	2
0.4 Delimitation of the system - - - - -	2
<b>1 Product description</b>	<b>1</b>
1.1 Application - - - - -	1
1.2 Safety measures - - - - -	1
1.3 Operating instructions for connectable equipment - - - - -	1
1.4 Name plate - - - - -	1
1.5 EC declaration of conformity - - - - -	2
1.6 Technical data - - - - -	3
1.7 Hydraulics - - - - -	4
1.8 Electrical system - - - - -	5
1.9 Noise exposure (noise level) - - - - -	6
1.10 Scope of supply - - - - -	6
<b>2 Safety instructions</b>	<b>1</b>
2.1 General- - - - -	1
2.2 General safety rules - - - - -	1
2.3 Safety principles - - - - -	2
2.4 Responsibility - - - - -	3
2.5 Generally applicable warnings of residual dangers - - - - -	5
<b>3 Design and function</b>	<b>1</b>
3.1 General- - - - -	1
3.2 Design AU Drive Unit - - - - -	2
3.3 Function - - - - -	4
<b>4 Operating elements and displays</b>	<b>1</b>
4.1 Controls - - - - -	1
4.2 Displays - - - - -	2
<b>5 Operation</b>	<b>1</b>
5.1 Personnel qualifications - - - - -	1
5.2 System requirements - - - - -	1
5.3 Connectable pressing tools - - - - -	1
5.4 Preparatory operations - - - - -	2
5.5 Procedure - - - - -	5
<b>6 Servicing</b>	<b>1</b>
6.1 Servicing and maintenance table- - - - -	1
<b>7 Corrective maintenance</b>	<b>1</b>
7.1 Troubleshooting - - - - -	1
7.2 Storage- - - - -	2

<b>8</b>	<b>Transport</b>	<b>1</b>
8.1	Transport - - - - -	1
8.2	Safety instructions - - - - -	1
8.3	Crane shackles and transport handles - - - - -	2
<b>9</b>	<b>Disposal</b>	<b>1</b>
9.1	General - - - - -	1
9.2	Disposal regulations - - - - -	2
9.3	Disposal - - - - -	2

# 0 Introduction

## 0.1 Congratulations!

You have decided to purchase a tried and tested TYROLIT Hydrostress AG system and have thus acquired a highly sophisticated and reliable state-of-the-art unit.

Thanks to the emphasis we place on quality assurance, your TYROLIT Hydrostress AG system is another top-of-the-range Swiss product:

- High performance
- Reliable operation
- High portability
- Easy handling
- Low maintenance costs

Only original TYROLIT Hydrostress AG spare parts can guarantee quality and interchangeability.

In the case of neglected or inappropriate maintenance, we will be unable to accept the warranty commitment as specified in our terms of delivery.

Any repair work must be carried out by trained personnel only.

If you need more details about how to keep your TYROLIT Hydrostress AG system in perfect condition, please contact our after-sales service for further information.

We hope that working with your TYROLIT Hydrostress AG system will be a problem-free and fault-free experience.

TYROLIT Hydrostress AG

Management

Copyright © TYROLIT Hydrostress AG, May 2009

**TYROLIT Hydrostress AG**  
**Witzbergstrasse 18**  
**CH-8330 Pfäffikon**  
**Switzerland**  
**Phone +41 (0) 44 / 952 18 18**  
**Fax +41 (0) 44 / 952 18 00**

## **0.2 Validity of these Operating Instructions**

This manual is only valid for the following system:

**AU drive unit**

## **0.3 Standards**

These Operating Instructions have been prepared in accordance with the CE Machinery Directive Appendix I and with the relevant standards in force at the time of printing.

## **0.4 Delimitation of the system**

These Operating Instructions describe the use of the AU drive unit.

# 1 Product description

## 1.1 Application

The AU drive unit has been designed as a component for concrete pressing systems:

The applicable mandatory limitations on use and other parameters are contained in Chapter 1 "Technical data" 1.6, 1-3

## 1.2 Safety measures

Any use other than for the intended purpose (see Chapter 1.1, 1-1) constitutes abuse or misuse.

## 1.3 Operating instructions for connectable equipment

In order to ensure safety in the workplace and in danger areas, as well as the safe operation of connectable equipment, the relevant Operating Instructions must in all cases be followed.

## 1.4 Name plate

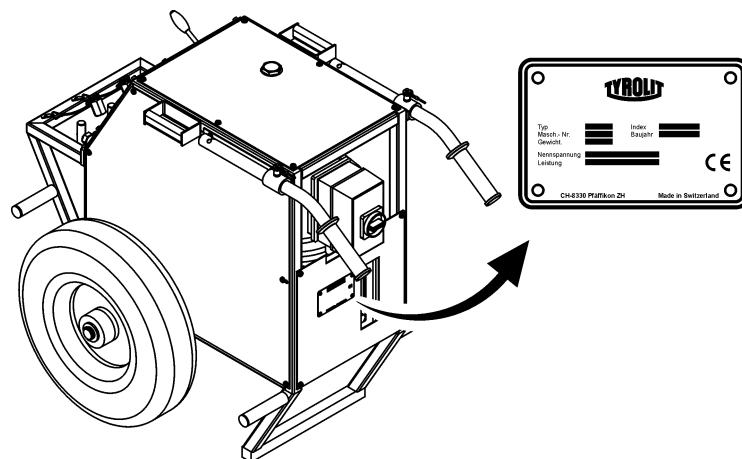

Fig. 1-1 Name plate

## 1.5 EC declaration of conformity

Description	Hydraulic drive unit
Type designation	AU drive unit
Year of construction	1981

We declare under our own liability that this product complies with the following directives and standards:

### 1.5.0.1 Directive applied:

European Machinery Directive (Machinery Directive) 98/37/EEC  
European Low Voltage Directive 73/23/EEC  
EN 2002/96/EC Waste electrical and electronic equipment

### 1.5.0.2 Standards applied:

EN 12100-1	Safety of machinery – Basic concepts, general design
EN 12100-2	principles
EN 294	Safety of machinery – Safety distances to prevent upper limbs reaching danger areas.
EN 349	Safety of machinery – Safety distances to avoid crushing of body parts.
EN 982	Safety of machinery Safety requirements of safety systems and their components – Hydraulics
EN 60204-1	Safety of machinery – Electrical equipment of machines



## 1.6 Technical data

### 1.6.1 Dimensions

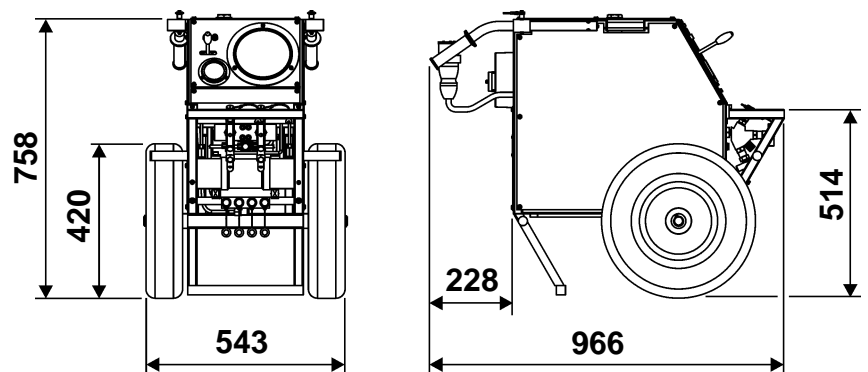

Fig. 1-2 Measurements in mm

### 1.6.2 Weight

Operating weight 95 kg

### 1.6.3 Tyres

Wheel Ø 42 cm

Operating pressure 3 bar

## 1.7 Hydraulics

### 1.7.1 Hyrdraulic circuits

3 closed circuits

- High pressure circuit           max. 2,000 bar
- Pressure booster circuit       max. 80 bar
- Low pressure circuit           max.150 bar

### 1.7.2 Flow rates and pressure

30 l/h 2,000 bar

### 1.7.3 Connection options

With high-pressure 4-way distributor 4 pressing-tools  
With special accessory max. 8

### 1.7.4 Press force

max. 2,000 bar

### 1.7.5 Radial piston pump

Primary outlet       14.4 l/min, 80 bar  
Secondary outlet    2.4 l/min, 150 bar

### 1.7.6 Oil tank

Oil tank volume:    13 litres  
Filter quality:       25 µm

### 1.7.7 Return oil filter

Type:                Filter screen

### 1.7.8 Oil quality

TYROLIT Hydrostress AG recommends:

**Hydraulic oil: HLP/ISO VG 46**

## 1.8 Electrical system



Information
<p>Electrical data are only valid for the installed loads                      3 P / LNPE 400 VAC / 50 Hz</p>



Warning
<p>A danger will arise if the AU drive unit is operated with a different mains network voltage.</p> <p>The details on the name plate must correspond to the mains network values (voltage and frequency).</p> <p>Damage may be caused to the unit if it is connected to a different voltage; there is also a risk of fire and personal injury.</p>

### 1.8.1 Motor

Electric motor	Air cooled
Power supply	3P / PE 380-420V / 50Hz
Current consumption	10 A at maximum load 3 x 200 V 50 Hz / 60 Hz 3 x 230 V 50 Hz 3 x 400 V 50 Hz 3 x 460 V 60 Hz
Output	2.2 kW
Speed	at 50 Hz 2,850 rpm at 60 Hz 3,480 rpm

#### 1.8.1.1 Motor protection

Electrical protection	Thermal relay
-----------------------	---------------

#### 1.8.1.2 Cooling

Air cooling

#### 1.8.1.3 Protection class

IP 44

## 1.9 Noise exposure (noise level)

Depending on the working environment and the connected device, the AU drive unit can produce high noise levels during operation.



### Danger

#### Noise danger

**When operating the AU drive unit, the wearing of hearing protection is mandatory at all times.**

**If this instruction is not followed irreparable hearing damage may result.**

### 1.9.0.1 Noise level measurement

Noise level measured at the ear of the operator 0.5 m from the AU drive unit; noise power level according to ISO 3744; drive unit only; highest value taken from all operating states at full load; mean values from three series of measurements.

**Noise level 83 dB (A) noise power level 92 dB (A)**

## 1.10 Scope of supply

- AU drive unit
- Operating Instructions / Spare parts list

## **2 Safety instructions**

### **2.1 General**

All persons who work on and with the AU drive unit have a duty to read and understand the operating instructions.

#### **2.1.1 Observance of the safety instructions**

The AU drive unit has been inspected before being shipped and is delivered in perfect condition. TYROLIT Hydrostress AG does not accept any liability for damage caused by the failure to observe the instructions and information provided in the operating instructions. This applies in particular to:

- Damage caused by improper use and operator error.
- Damage caused by failure to observe safety-related information in the operating instructions or shown on the warning signs attached to the machine.
- Damage caused by defective or neglected maintenance work.

Independently performed conversions and alterations may affect safety and are not permitted.

### **2.2 General safety rules**

#### **2.2.1 Statutory provisions**

The generally applicable national and local safety and accident prevention provisions and the supplementary operator regulations must be followed and complied with.

#### **2.2.2 Inspection and maintenance obligation**

The operator is under an obligation to use the AU drive unit only when it is in a perfect and undamaged condition. The maintenance intervals shown in the Operating Instructions must be adhered to without fail. Malfunctions and mechanical damage must be rectified without delay.

#### **2.2.3 Spare parts**

Only TYROLIT Hydrostress AG original spare parts may be used. Otherwise, damage can be caused to the AU drive unit or other property and may result in personal injury.

#### **2.2.4 Power connections**

The AU drive unit must be connected and coupled in accordance with the operating instructions.

## **2.3 Safety principles**

### **2.3.1 Delimitation of the safety concept**

The AU drive unit does not affect the safety concept of the connected systems, equipment and installations.

### **2.3.2 Safety elements**

#### **Protection from live electrical parts**

All functional units containing parts which carry hazardous voltages are shock-protected by suitable covers.

### **2.3.3 Removal of protective devices**

Protective devices may only be removed if the unit has been switched off, disconnected from the mains and is at standstill. Safety components, in particular, may only be removed and refitted by authorised personnel, see "Chapter 2" 2.4.1, 2-3.

Before switching the AU drive unit back on again, the safety elements must be checked to ensure correct operation.

### **2.3.4 Safety measures (organisational)**

#### **2.3.4.1 Product monitoring obligation**

Operating personnel must notify changes in operational behaviour or safety-related components to a responsible person or the manufacturer, immediately.

#### **2.3.4.2 Location of the Operating Instructions**

A copy of the Operating Instructions must be available to staff at all times at the place of use of the equipment.

## **2.4 Responsibility**

### **2.4.1 Authorised personnel**

Work on or with the TYROLIT Hydrostress AG machines or systems may only be performed by authorised personnel. Personnel are considered by TYROLIT Hydrostress AG to be authorised if they meet the necessary training and know-how requirements and they have been assigned a precise functional role.

The personnel qualifications for the corresponding work are contained in the introduction under "General" of the respective chapters.

### **2.4.2 Manufacturer**

TYROLIT Hydrostress AG or a company expressly nominated by TYROLIT Hydrostress AG is deemed to be the manufacturer of the products supplied by TYROLIT Hydrostress AG. Within the context of an integrated quality assurance and safety control system, the manufacturer is entitled to request from the operator information about the products.

### **2.4.3 Operator**

The operator named by TYROLIT Hydrostress AG is the primary, legal entity responsible for the designated correct use of the product and for the training and assignment of the authorised personnel. The operator sets out the mandatory skills and level of training of the authorised personnel for his company.

### **2.4.4 Operator (user)**

User is the term employed by TYROLIT Hydrostress AG to designate a person who independently performs the following work:

- Sets up TYROLIT Hydrostress AG machines or systems for tasks according to the intended purpose.
- Performs tasks independently and monitors these.
- Locates malfunctions and initiates or performs troubleshooting.
- Carries out servicing and simple maintenance.
- Monitors the correct functioning of the safety devices.

### **2.4.5 Service engineers**

Service engineer is a term used by TYROLIT Hydrostress AG to designate a person who independently performs the following work:

- Installs TYROLIT Hydrostress AG machines and systems and controls their correct application.
- Makes adjustments to machines and systems for which special access rights are required.
- Performs repairs, complex service work and maintenance work.

## **2.4.6 Qualification and training**

### **2.4.6.1 Operator**

- A technically trained person in a management position.
- Has relevant experience in personnel management and danger assessment.
- Has read and understood the "Safety instructions" chapter.

### **2.4.6.2 Operator (user)**

- Have trained as a concrete cutting expert or have professional experience.
- Has received an introduction (basic training) to the operation of the TYROLIT Hydrostress AG machines and systems from a service engineer.
- Have read and understood Chapter 2 "Safety instructions".

### **2.4.6.3 Service engineers**

- Has specialist professional training (mechanical / electrotechnical).
- Has attended specialist courses at TYROLIT Hydrostress AG.
- Has read and understood the "Safety instructions" chapter.



## 2.5 Generally applicable warnings of residual dangers



### Danger

**Electric shock due to defective electronic equipment.**

The electrotechnical equipment must be checked prior to each use and from time to time during prolonged use. Defective parts, such as e.g. cables and plugs, must be replaced immediately in the de-energized state by electrotechnically trained personnel.

Failure to comply with this regulation may lead to serious physical injury or death. Secondary damage such as fires may also occur.



### Warning

**Danger of allergic reactions if skin comes into contact with hydraulic oil.**

Persons who have an allergic reaction to hydraulic oil must wear protective gloves and goggles when carrying out work where they come into contact with hydraulic oil. Any areas of the skin affected must be rinsed immediately with copious amounts of water.

Failure to observe this regulation may result in allergic reactions or injury to the eyes.



### 3 Design and function

#### 3.1 General

The AU drive unit is assembled from other TYROLIT components to form a complete pressing system.

##### 3.1.1 System components

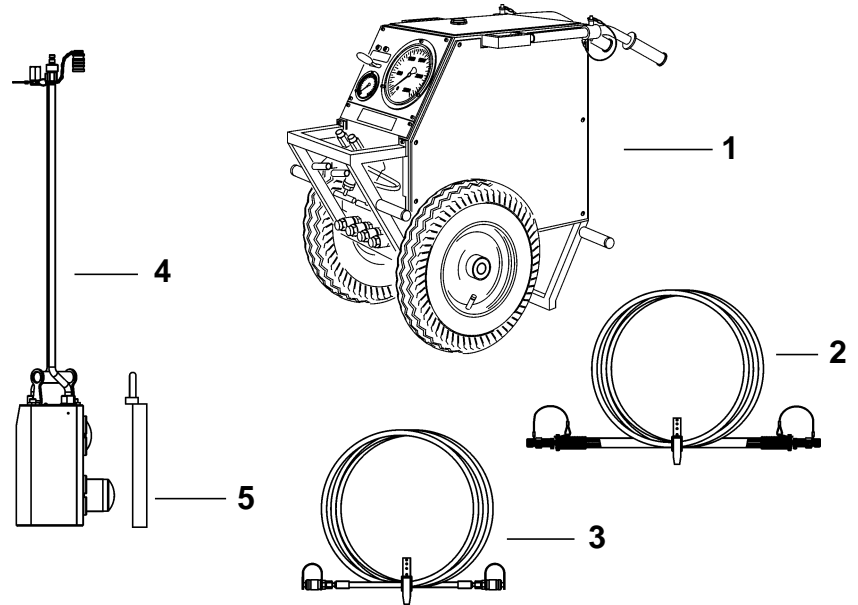

Fig. 3-1 System components

- |                      |                  |
|----------------------|------------------|
| 1 Drive unit         | 4 Pressing tool  |
| 2 High-pressure hose | 5 Pressing plate |
| 3 Low-pressure hose  |                  |

## Warning



**Danger from incorrect system components.**

**The AU drive unit should only be operated with original TYROLIT Hydrostress AG- system components.**

**Failure to adhere to this regulation may result in physical injury and damage to property.**

## 3.2 Design AU drive unit

### 3.2.1 Components

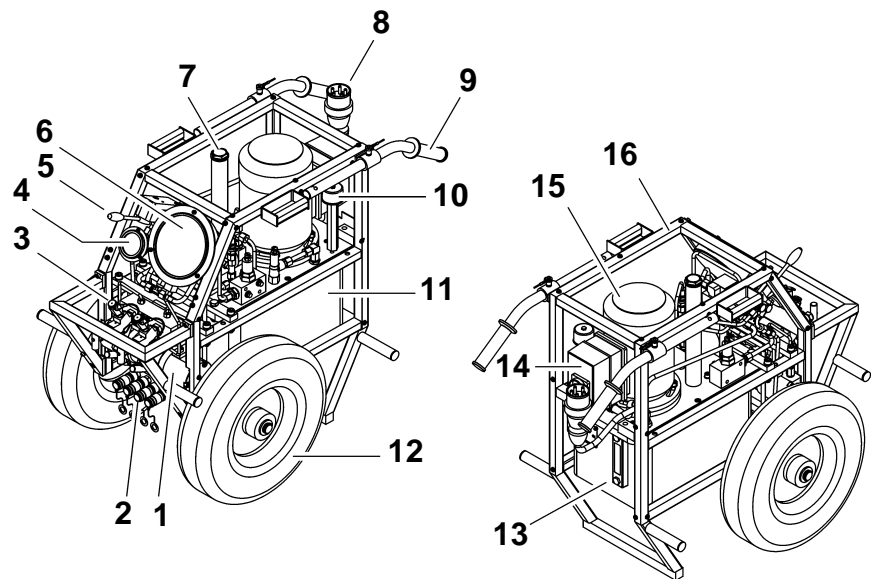

Fig. 3-2 Components

- |   |                         |
|---|-------------------------|
| 1 Pressure booster                            | 10 Vent connection      |
| 2 Return connection (screw connection)        | 11 Oil tank             |
| 3 High-pressure connection (screw connection) | 12 Wheel                |
| 4 Low pressure gauge                          | 13 Oil level indication |
| 5 Control valve                               | 14 Electrical box       |
| 6 High pressure gauge                         | 15 Electric motor       |
| 7 Oil filler neck                             | 16 Chassis              |
| 8 Mains cable                                 |                         |
| 9 Grip  |                         |

### 3.2.2 Wiring diagram

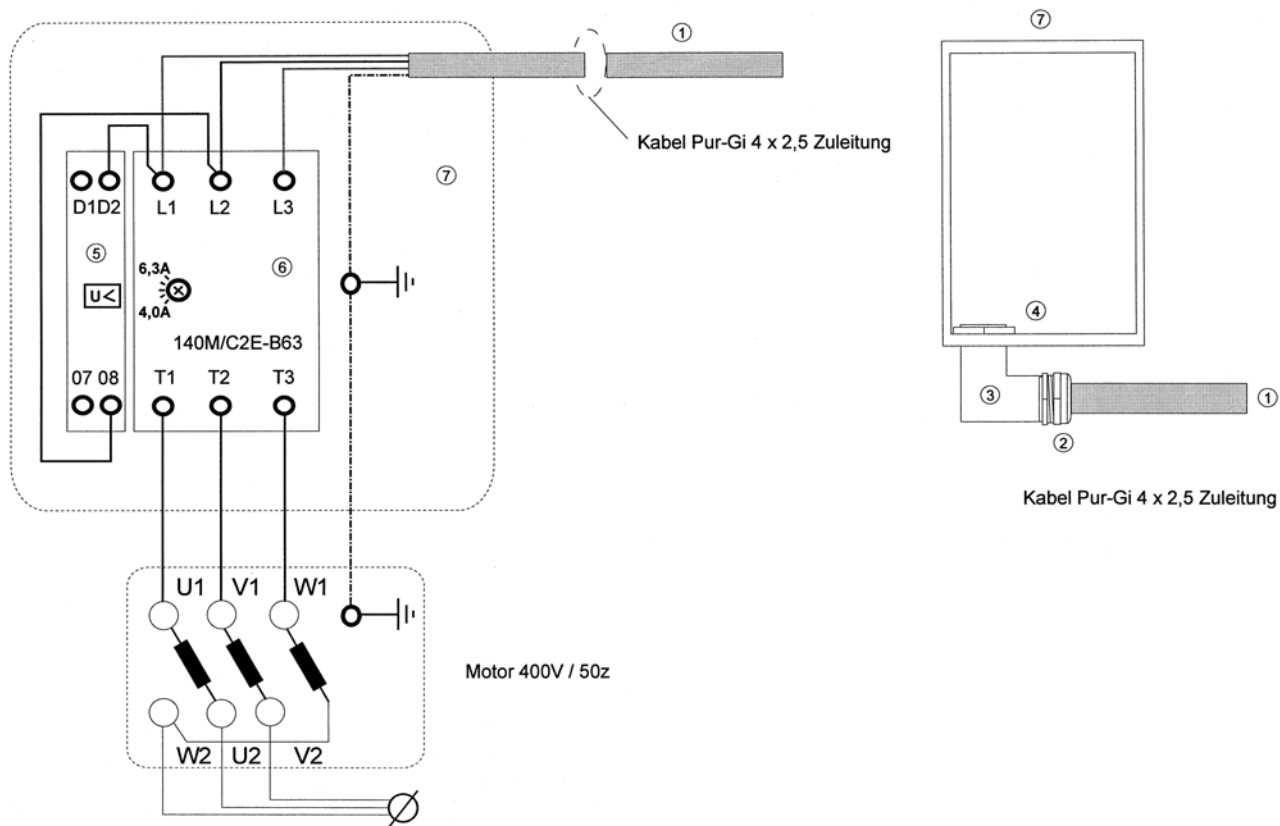

Fig. 3-3 Wiring diagram

### 3.3 Function

#### 3.3.1 Hydraulic circuit diagram

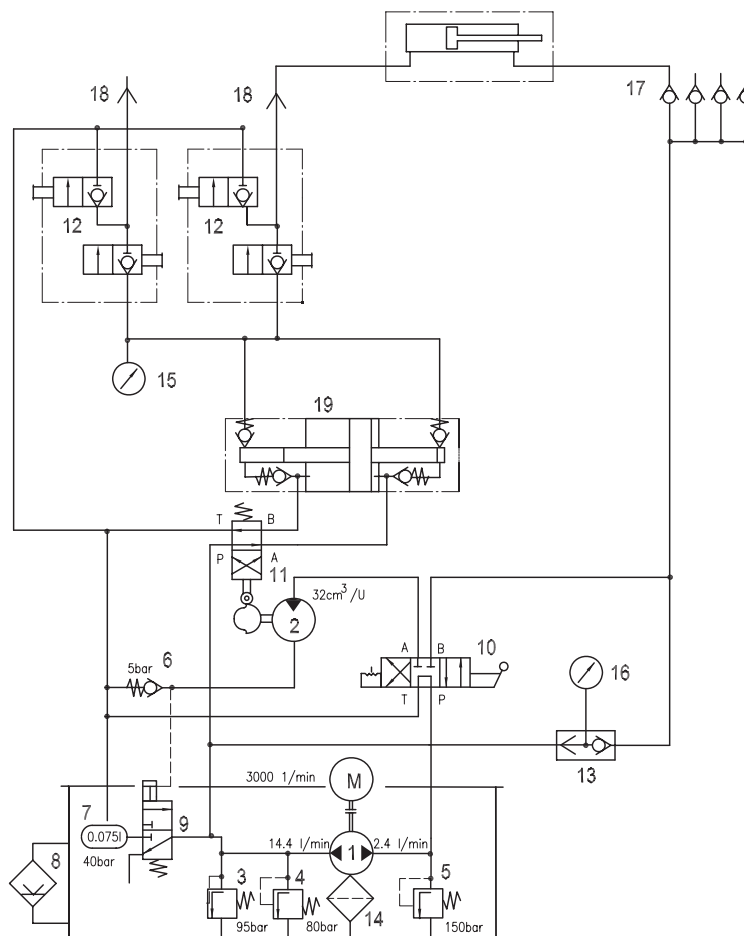

Fig. 3-4 Hydraulic circuit diagram

- |                                  |                                  |
|----------------------------------|----------------------------------|
| 1 Radial piston pump             | 12 High-pressure 3-way valve     |
| 2 Hydraulic motor                | 13 Shuttle valve                 |
| 3 Pressure relief valve MVS 41 E | 14 Suction filter                |
| 4 Pressure relief valve MVE 5 F  | 15 Pressure gauge 0 - 2,500 bar  |
| 5 Pressure relief valve MVE 5 E  | 16 Pressure gauge 0 - 250 bar    |
| 6 Check valve                    | 17 Screw connection              |
| 7 Accumulator                    | 18 High-pressure threaded nipple |
| 8 Oil level                      | 19 High-pressure booster         |
| 9 3 / 2 way valve                |                                  |
| 10 4 / 3 way valve               |                                  |
| 11 4 / 2 way valve               |                                  |

### 3.3.2 Functional description for the hydraulic circuit diagram

The switch box provides the voltage for the electric motor M. The electric motor constantly drives the radial piston pump (1).

The radial piston pump draws the hydraulic oil from the oil tank via the suction filter (14) and supplies the three closed hydraulic circuits via two outlets (primary and secondary sides):

- Low-pressure circuit for driving the cadence motor (2) and for piston return.
- Pressure booster circuit for driving the pressure booster (19).
- High-pressure circuit for pressing.

The circuits are activated by the control valve (10).

Control valve in position 0 (circulation): The hydraulic oil is circulated unpressurised. The secondary outlet from the control valve (10), the primary outlet via the 3/2-way valve (9) into the oil tank.

Control valve in position I (pressing): The secondary outlet drives the cadence motor (2) and operates the 3/2-way valve (9). If the 3/2-way valve (9) is operated, the hydraulic oil flows from the primary outlet via the cadence valve (11) to the pressure booster (19). Via the pulse generator the cadence motor (2) operates the cadence valve (11) and this operates the pressure booster (19).

If the red stop valve of the high-pressure valve (12) is opened and the blue stop valve is closed, the piston of the pressing tool has pressure applied to it and extends.

Return takes place via the screw connection (17) and the control valve (10) in the oil tank. By means of the red stop valve and the blue pressure control valve the pressing tools can be pressurised or depressurised individually. The oil pressure can also be maintained and retained.

Control valve in position II (return): By means of the secondary outlet and the control valve (10) the pistons of the pressing tools are pressurised on the low pressure side and withdraw. The hydraulic oil from the primary outlet flows via the 3/2-way valve (9) unpressurised into the oil tank.

The accumulator (7) in the pressure booster circuit balances out any variations in pressure. The shuttle valve (13) controls the display on the pressure gauge (16) (pressure booster or low-pressure circuit).





## 4 Operating elements and displays

### 4.1 Controls

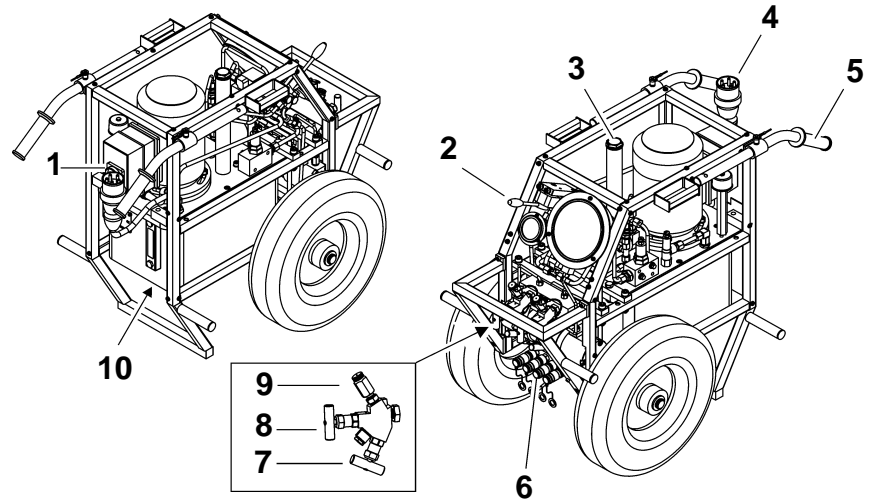

Fig. 4-1 Operating elements

Pos.	Description	Marking	Function
1	Main switch		Switches unit ON/OFF
2	Control valve	I / 0 / II	Position I: Pressing Position 0: Unpressurised circulation Position II: Piston return
3	Tank connection	Hydraulic oil	Filling with hydraulic oil
4	Mains cable		For mains cable see 1.8.1, 1-5
5	Handle		Transport
6	Low-pressure connection		Low-pressure hose connection Plug connector
7	Stop valve	red	Open: Pressing and return possible Closed: No pressing process possible
8	Pressure control valve	blue	Open: Pressure in the high-pressure circuit is reduced to zero Closed: Pressure builds up in the high-pressure circuit
9	High-pressure connection		High pressure hose screw connection
10	Oil drain screw		Empty tank

## 4.2 Displays

### 4.2.1 Overview

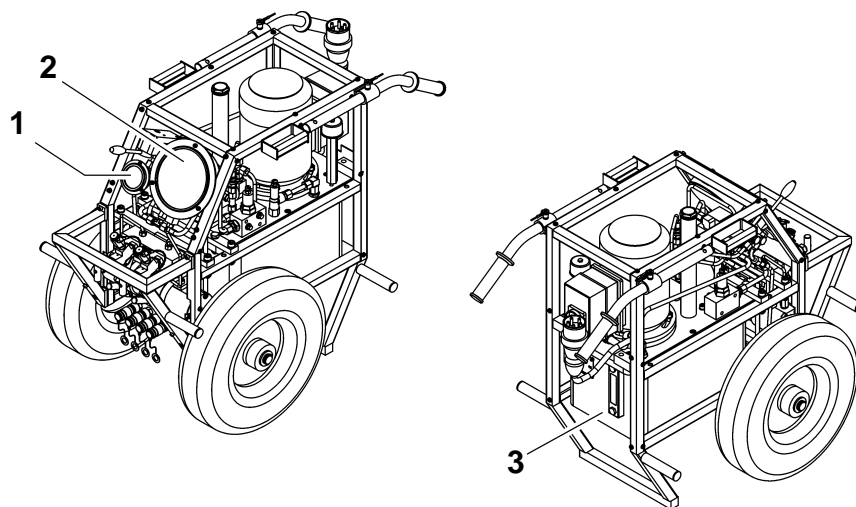

Fig. 4-2 Displays

- 1 Low pressure gauge
- 2 High pressure gauge
- 3 Oil level indication

### 4.2.2 Low pressure gauge (0 - 250 bar)

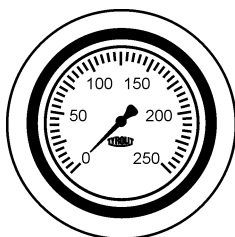

Fig. 4-3 Low pressure gauge

### 4.2.3 High pressure gauge (0 - 2,500 bar)

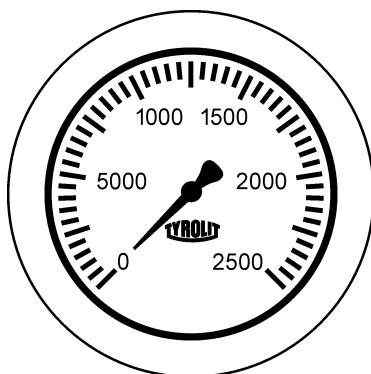

Fig. 4-4 Low pressure gauge

### 4.2.4 Oil level indicator

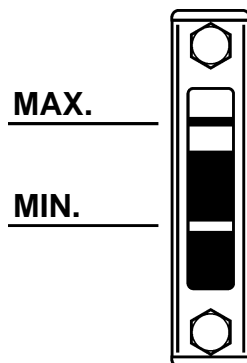

Fig. 4-5 Oil level indicator



Information	
<p>The quantity of oil between OIL MIN and OIL MAX is 6.5 litres.</p> <p>The oil level must be checked with the hoses disconnected.</p> <p>Different types of hydraulic oil should not be mixed together, otherwise the oil will age prematurely.</p> <p>Recommended hydraulic oil: HLP / ISO VG 46</p>	



## 5 Operation

### 5.1 Personnel qualifications

The AU drive unit must not be operated by unauthorised personnel. Personnel are only authorised if they meet the following requirements.

- Have trained as a concrete cutting expert or have professional experience.
- Have received an introduction (basic training) to the operation of the AU drive unit from a service engineer.
- Have read and understood Chapter 2 “Safety instructions”.

### 5.2 System requirements

#### Warning



**A danger will arise if the AU drive unit is operated with a different mains network voltage.**

**The details on the name plate must correspond to the mains network values (voltage and frequency).**

**The system may be damaged by connecting it to a different voltage. There is also a danger of fire and injury.**

### 5.3 Connectable pressing tools

Up to 4 original TYROLIT Hydrostress AG pressing tools can be connected to the AU drive unit using a distribution piece.

#### Danger



**Danger from hydraulic oil leaks.**

**Only original TYROLIT Hydrostress AG pressing tools and original high- and low-pressure hoses should be connected to the AU drive unit.**

**Failure to observe this regulation may lead to serious physical injury, possibly even death, and to property damage.**

## 5.4 Preparatory operations

### 5.4.1 Visual inspection

Before starting work always complete the following visual inspections:

- Is the power supply earthed, fitted with a neutral conductor and a residual current circuit breaker?
- Does the mains network have the correct fuse protection?

Design	Fuse protection	Cable cross section
380 - 420 V / 50Hz	16 A	5x2.5 mm <sup>2</sup> (from 25 to 50 m 5x4 mm <sup>2</sup> )
230 V / 50Hz	16 A	5x2.5 mm <sup>2</sup> (from 25 to 50 m 5x4 mm <sup>2</sup> )
200 V / 50 / 60Hz	16 A	5x2.5 mm <sup>2</sup> (from 25 to 50 m 5x4 mm <sup>2</sup> )
460 - 480 V / 60 Hz	16 A	5x2.5 mm <sup>2</sup> (from 25 to 50 m 5x4 mm <sup>2</sup> )

- Is there sufficient oil in the AU drive unit?
- Is there any damage to cables or plugs?

### 5.4.2 Connecting the AU drive unit

#### 5.4.2.1 Hydraulic connections

Each pressing tool is connected to the AU drive unit by means of a high-pressure hose fitted with a special press connector.



#### Information

The high-pressure hose is connected by means of a screw connector. The low-pressure hose is connected by means of a plug-in coupling.



#### Warning

**Danger from uncontrolled movements and uncontrolled escape of oil.**

**Never connect or disconnect hoses while the drive unit is running.**

**Failure to observe this regulation may result in cut wounds or injury to body parts as well as damage to property.**

**Screw connection:**

Fig. 5-1 Screw connection

**In order to connect the high-pressure hose proceed as follows:**

- A Remove the protective cap
- B Rotate the hydraulic end piece as far as the stop (X max.)
- C Screw the hydraulic hose to the AU drive unit

**Danger**

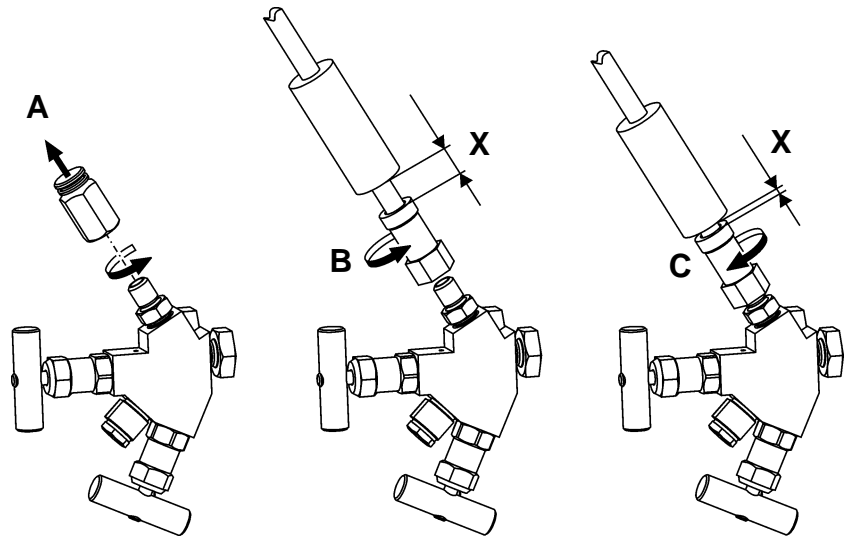
**Danger from hydraulic oil leaks.**

**Securely tighten the screwed connection with a fork wrench. If after tightening the adjusting nut a distance X is no longer available then the adjusting nut and the threaded nipple must be exchanged.**

**Failure to observe this regulation may lead to serious physical injury, possibly even death, and to property damage.**

**Plug-in coupling:**

Fig. 5-2 Plug-in coupling

**In order to connect the low-pressure hose proceed as follows:**

- A Remove the protective coupling
- B Pull back the coupling ring
- C Attach coupling piece and slacken coupling ring

**Information**

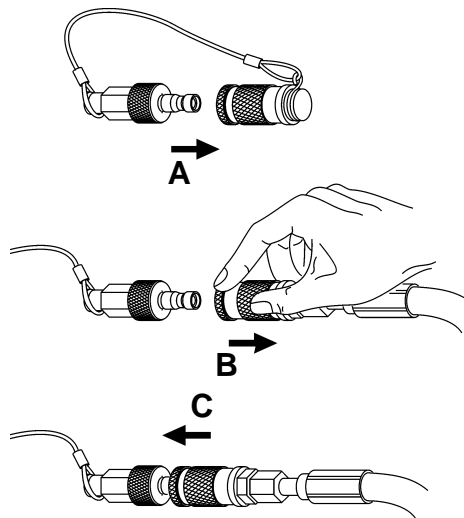
Always connect the return hose of the pressing tool first. Ensure that the return hose coupling has correctly latched.



## 5.5 Procedure

### 5.5.1 Before switching on



#### Information

The AU drive unit should only be switched on in a level and upright position.



#### Information

On no account use force to close the stop valve and the pressure control valve. Simply tighten gently with your fingers.



#### Information

If a high-pressure valve is not used, its shut-off valve must be closed.

### 5.5.2 Default settings

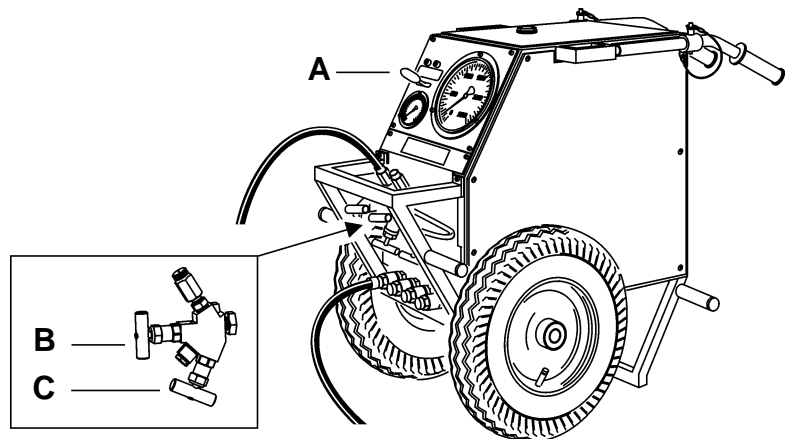

A Control valve in position 0

B Pressure control valve (blue) open

C Stop valve (red) of the connected high-pressure circuit open

### 5.5.3 Starting work

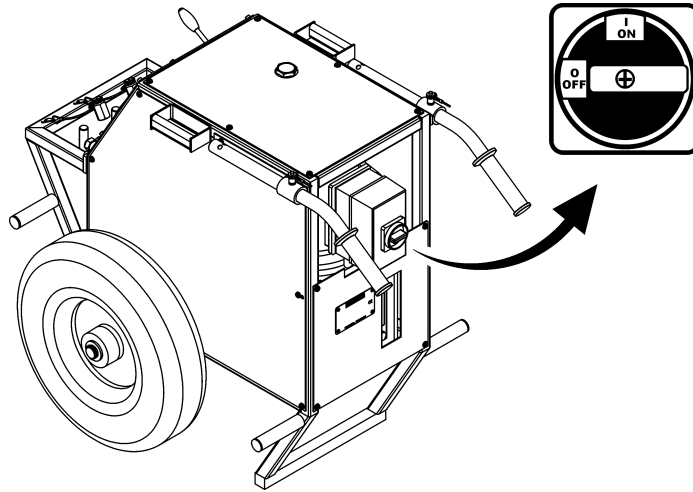

Fig. 5-3 Main switch

**Proceed as follows:**

1. Connect AU drive unit to the mains power supply
2. Turn main switch to ON, the AU drive unit starts.



Information
If the electric motor does not start, check the power supply.

3. Control valve in position I, pressing
4. Slowly close the pressure control valve (blue)

The pressing tool is pressurised and the pressing pistons extend. Check the pressure display on the high-pressure gauge. The maximum permitted pressure is 2,000 bar.

5. Control valve in position 0
6. Open pressure control valve (blue), in order to fully depressurise the pressing tool.

7. Control valve in position II

The pressing pistons withdraw. Check the pressure display on the low-pressure gauge. The maximum permitted pressure is 150 bar.

8. Place the control valve in position 0.



Information
If the piston travel is insufficient, repeat steps 1 to 6 with an additional pressure plate.

### 5.5.4 Terminating the work

1. Turn main switch to OFF, the AU drive unit stops.
2. Remove plug from the mains
3. Open the pressure control valve (blue)



#### Warning

**Danger from uncontrolled movements and uncontrolled escape of oil.**

**Never connect or disconnect hoses while the drive unit is running.**

**Failure to observe this regulation may result in cut wounds or injury to body parts as well as damage to property.**

4. Before disconnecting the hoses switch the control valve back and forth between positions I and II a few times. This eliminates any residual pressure from the return hose.
5. Remove the high-pressure hose. Immediately fit the protective cap to the high-pressure hose.
6. Disconnect the low-pressure hose. Immediately fit the protective cap.



#### Information

Always keep hose couplings clean. Do not allow them to drop.

In order to avoid damaging the couplings, do not drag the hoses across the floor.



## 6 Servicing

### 6.1 Servicing and maintenance table

		before each start-up	upon completion of work	weekly	annually	in the event of malfunction	in the event of damage
Hydraulic system	Hydraulic hose inspection (leakproof condition / cleanliness)	X	X			X	X
	Coupling inspection (leakproof condition / cleanliness)	X	X			X	X
	Check oil level, see "Chapter 4" 4.2.4, 4-3	X	X			X	
	Replace hydraulic oil, see "Chapter 6" 6.1.1, 6-2	Part of Major Service					
	Clean or exchange suction filter						
Mechanical	Retighten accessible screws and nuts			X		X	
Major service First service after 100 operating hours After every 200 operating hours, thereafter	May only be carried out by TYROLIT Hydrostress AG or an authorised representative						

### 6.1.1 Oil change

#### 6.1.1.1 Oil quality

TYROLIT Hydrostress AG recommends:

**Hydraulic oil:** HLP / ISO VG 46

Other hydraulic oils can be used if they comply with the following specifications:

Pour point:	-42° C
Viscosity index:	170
Viscosity class:	HLP VG 46 or ISO 3498 HV 46
Wear-protection according to DIN 51524 Part 3 (HV46)	



Information
Different types of hydraulic oil should not be mixed together, otherwise the oil will age prematurely.

#### 6.1.1.2 Replacing hydraulic oil

**In order to replace the hydraulic oil you will need:**

- A collecting pan for the used hydraulic oil with a capacity of approx. 15 litres
- Open-ended spanner, size across flats 10 mm for the oil drain plug
- Approx. 13 litres of hydraulic oil

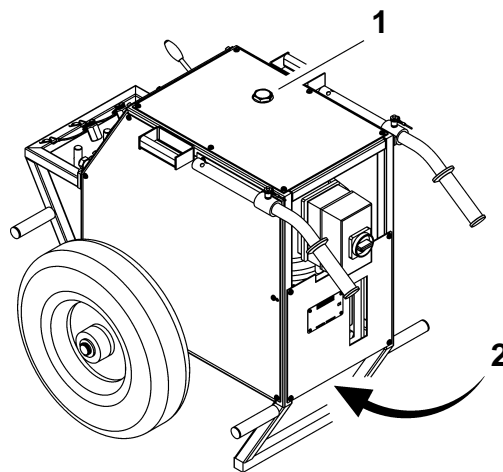

Fig. 6-1 Replacing hydraulic oil

- 1 Tank cover
- 2 Oil drain plug

**Proceed as follows:**

- Place the collecting pan below the oil drain plug (2)
- Open tank cover (1)
- Remove oil drain plug (2)
- Drain hydraulic oil completely
- Screw in oil drain plug (2)
- Fill tank with new hydraulic oil
- Bleeding the system
- Close tank cover (1)
- Dispose of waste hydraulic oil in accordance with local regulations

**6.1.1.3 Bleeding the system****Information**

Air must be bled from the system whenever the tank has been completely emptied and refilled.

**Proceed as follows:**

- Open tank cover
- Fill oil to maximum mark
- Do not refit the tank cover, yet
- Open pressure control valve (blue) and stop valve (red)
- Switch control valve to position I, pressing
- Allow the AU drive unit to run for a maximum of 5 seconds
- Switch off the AU drive unit, see "Chapter 5" 5.5.4, 5-7
- Wait for one minute
- Repeat the start-up and shutdown process three times
- Check the oil level and top up the hydraulic oil as necessary
- Fit tank cover
- The system is now free of air





## 7 Corrective maintenance

### 7.1 Troubleshooting

The following table will help you to narrow down and rectify the source of the fault.

Malfunction	Possible cause	Solution
AU drive unit does not run, although the mains cable is connected	Main switch in position 0	Switch on the AU drive unit
	No voltage at drive unit because:	
	Automatic circuit breaker in electric controller has tripped	- Reset automatic circuit breaker - Have the mains network checked
	Mains cable is defective	Replace the mains cable
	No voltage at the power supply (building site)	Check power supply
	Power supply phases incorrectly connected	Check power supply
The AU drive unit starts and then switches off again	Phase missing	Check power supply
	Fuse of building site power supply trips	- Fuse protection too weak - Change power supply
The AU drive unit starts and then switches off again	Incorrect voltage	The details on the name plate must correspond to the mains network values (voltage and frequency).
	Defective pressing tool	Inform TYROLIT Hydrostress AG after-sales service
No power, although electric motor is running and valves are open		
Oil leak	- Defective seal - Defective coupling	Inform TYROLIT Hydrostress AG after-sales service

Malfunction	Possible cause	Solution
The drive unit shuts down suddenly	Power supply interrupted because electric motor or thermal relay has overheated.  Reasons: - Undervoltage at the power supply - Overvoltage at the power supply - Cross section of power supply cable too small	Check power supply see "Chapter 1" 1.8.1, 1-5 Check power supply see "Chapter 1" 1.8.1, 1-5 Use mains cable with correct cross section, see "Chapter 5" 5.4.1, 5-2
	Defective plug connection	Check plug connection
No pressure build-up	Defective hydraulics	Inform TYROLIT Hydrostress AG after-sales service

If you are unable to remedy a fault, please call our service centre (see manufacturer's address on the reverse of the title page).

To guarantee a rapid and professional solution to the problem, it is important that you have prepared as follows before calling:

- Try to describe the fault as accurately as possible
- Note the type and index designation of your unit (name plate)
- Have the operating instructions close to hand

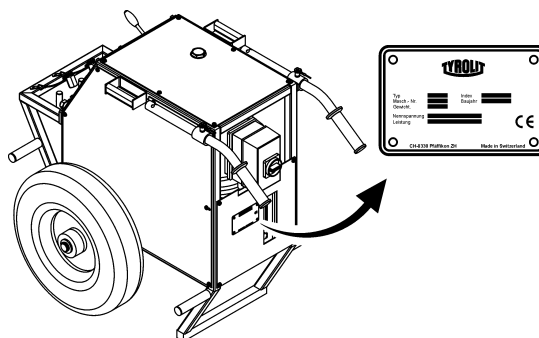

Fig. 7-1 Name plate

## 7.2 Storage

The AU drive unit consists partially of materials which can corrode. If you take the unit out of service for an extended period, proceed as follows:

- Lightly oil the unit
- Store in a dry location

## 8 Transport

### 8.1 Transport

The AU drive unit is a high-quality, technical device. Protect it against transport damage:

- Do not place any parts on or against the AU drive unit
- Protect the AU drive unit from impacts
- The AU drive unit must be secured against rolling away during transport

### 8.2 Safety instructions

It is essential to observe the following safety instructions, especially with regard to transport of the AU drive unit.



#### Danger

**Danger from incorrect crane transport**

**Crane transport should only be carried out using the crane shackles provided. Only undertake crane transport with serviceable building and mobile cranes**

**Failure to observe this regulation may lead to serious physical injury, possibly even death, and to property damage.**



#### Warning

**Danger from the lifting of heavy loads.**

**Units which weight more than 30 kg must not be lifted without suitable equipment.**

**For transport, use the handles provided. Always keep handles clean and free of grease.**

**Failure to adhere to this regulation may result in physical injury and damage to property.**

### 8.3 Crane shackles and transport handles

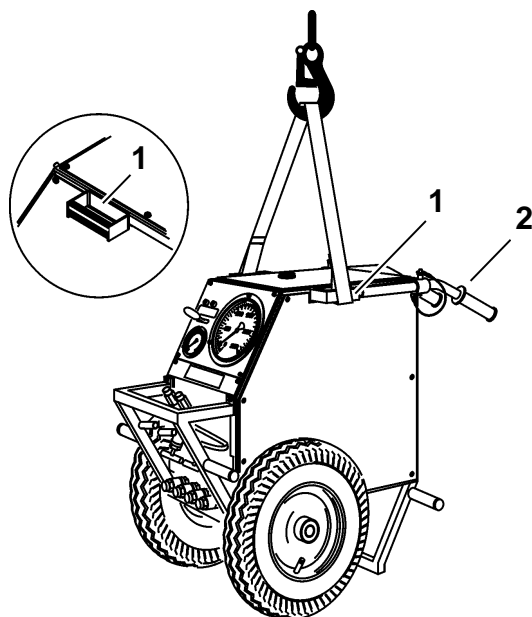

Fig. 8-1 Crane shackles and transport handles

- 1 Transport handle / Crane shackles
- 2 Transport handle

## Danger



**Danger of falling parts.**

**When crane transport is used, the AU drive unit must be transported alone (without hoses).**

**Failure to observe this regulation may lead to serious physical injury, possibly even death, and to property damage.**

## 9 Disposal

### 9.1 General

The operator can recycle or dispose of the AU drive unit himself provided that he observes the statutory provisions. In order to dismantle the unit correctly and to properly separate the materials, some knowledge of mechanical procedures and knowledge about the differentiation of waste materials is necessary.

Before proceeding read Chapter 2 "Safety instructions", 2-1 in these Operating Instructions. Be sure also to observe all the danger information given here and follow the instructions on how to prevent personal injury and damage to property.

#### 9.1.1 Safety instructions

It is essential to observe the following safety instructions, especially in relation to disposal of the AU drive unit:



### Danger

**Danger of falling heavy parts.**

**When performing the types of work described in this chapter, it is absolutely essential to wear the following personal protective equipment: goggles, protective gloves and safety shoes.**

**It is essential to ensure that the work instructions and procedures described in this safety manual are followed.**

**Failure to observe this regulation may lead to serious physical injury, possibly even death, and to property damage.**

#### 9.1.2 Personnel qualifications

Personnel who carry out the work described in this chapter must meet the following conditions:

- Have read and understood the safety instructions in "Chapter 2".
- Have completed their technical training (mechanical/electrotechnical) and are in a position to differentiate the various material groups.

## 9.2 Disposal regulations

The usual national and regional regulations and directives must be observed when disposing of the AU drive unit.

## 9.3 Disposal

To allow proper disposal, the components of the drive unit must be dismantled. This is performed by the client's personnel.

The dismantled parts of the device are sorted by material type and sent separately to the appropriate collection points. Ensure, above all, that the following parts are correctly disposed of.

### **The AU drive unit consists of the following materials:**

Cast aluminium	rolled aluminium products
Copper	steel
Rubber	rubber / nylon fabric
Synthetic grease	hydraulic oil
Plastic	